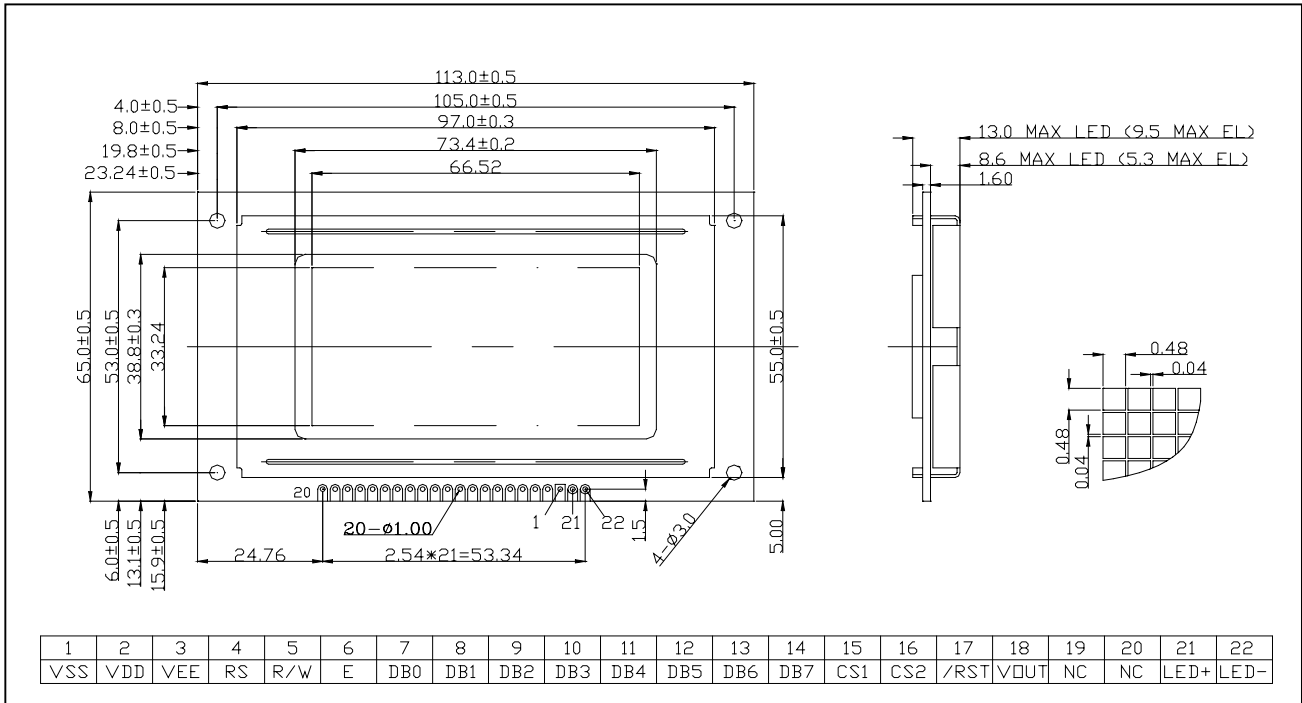

C12864-12
128 × 64DOTS
DIMENSION:

FEATURE:

1. Display mode : STN, Positive
2. Dot/Background Color : Blue/Yellow-green
3. Display format : 128×64dots
4. Input data : 8 bit I/O
5. Driving method : 1/64Duty 1/9Bias
6. Viewing direction : 6 O'clock
7. Back light : EL Green/LED Yellow-green

ELECTRICAL CHARACTERISTIC:

Item	Symbol	Standard value			Unit
		Min	Typ	Max	
Power supply for logic	VDD	-0.3	-	7.0	V
Power supply for LCD	VLCD	VEE-0.3	-	VDD+0.3	V
Input voltage	Vin	VSS	-	VDD	V
Operating temperature	Top	0	-	50	
Storage temperature	Tstg	-20	-	70	

BLOCK DIAGRAM:
