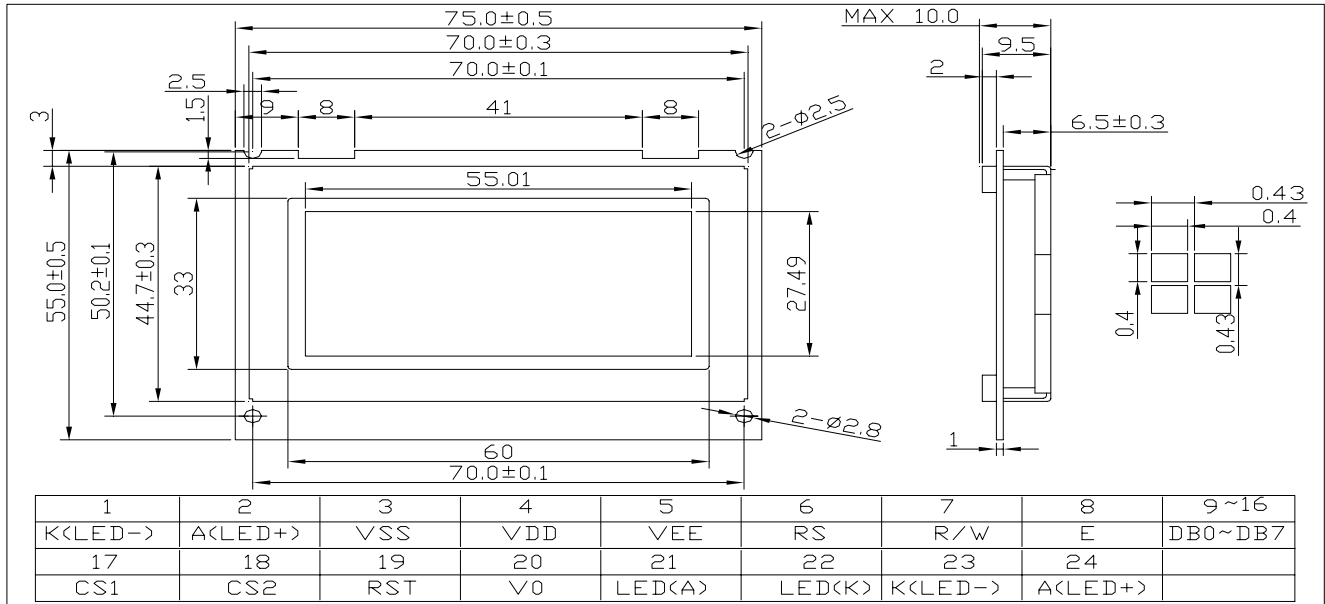

**C12864-18**
**128 × 64DOTS**
**DIMENSION:**

**FEATURE:**

1. Display mode : STN, Positive
2. Dot/Background Color : Blue/Yellow-green
3. Display format : 128×64dots
4. Input data : 8 bit I/O
5. Driving method : 1/64Duty 1/9 Bias
6. Viewing direction : 6 O'clock
7. Back light : EL Green/LED Yellow-green

**ELECTRICAL CHARACTERISTIC:**

Item	Symbol	Standard value			Unit
		Min	Typ	Max	
Power supply for logic	VDD	-0.3	-	7.0	V
Power supply for LCD	V <sub>LCD</sub>	VEE-0.3	-	VDD+0.3	V
Input voltage	V <sub>in</sub>	VSS	-	VDD	V
Operating temperature	T <sub>op</sub>	-20	-	70	
Storage temperature	T <sub>stg</sub>	-30	-	80	

**BLOCK DIAGRAM:**
